

Silicon Bipolar MMIC 1.5 GHz Variable Gain Amplifier

Technical Data

IVA-05208

Features

- **Differential Input and Output Capability**
- **DC to 1.5 GHz Bandwidth; 2.0 Gb/s Data Rates**
- **High Gain: 30 dB Typical**
- **Wide Gain Control Range: 30 dB Typical**
- **5 V Bias**
- **5 V V_{gc} Control Voltage, $I_{gc} < 3\text{mA}$**
- **Fast Gain Control Response: $< 10\text{ ns}$ Typical**
- **Low Cost Plastic Surface Mount Package**

Description

The IVA-05208 is a variable gain amplifier housed in a miniature low cost plastic surface mount package. This device can be used in any combination of single-ended or differential inputs or outputs (see Functional Block Diagram). The lowest frequency of operation is limited only by the values of user selected blocking and bypass capacitors.

Typical applications include variable gain amplification for fiber optic systems (e.g., SONET) with data rates up to 2.0 Gb/s, mobile radio and satellite receivers, millimeter wave receiver IF amplifiers and communication receivers.

SO-8 Package

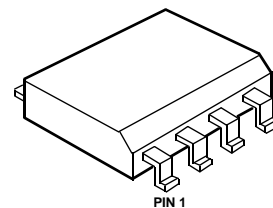

The IVA series of variable gain amplifiers is fabricated using HP's 10 GHz f_T , 25 GHz f_{MAX} ISOSAT™-I silicon bipolar process. This process uses nitride self-alignment, submicrometer lithography, trench isolation, ion implantation, gold metallization and polyimide inter-metal dielectric and scratch protection to achieve excellent performance, uniformity and reliability.

Typical Biasing Configuration and Functional Block Diagram

Differential Input/Differential Output

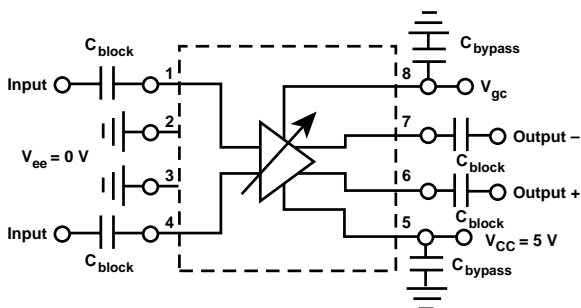

$C_{bypass} = 1000\text{ pF}$ typical
Good grounding of Pins 2, 3 is critical for proper operation and good VSWR performance of this part.

Single Ended Input/Single Ended Output

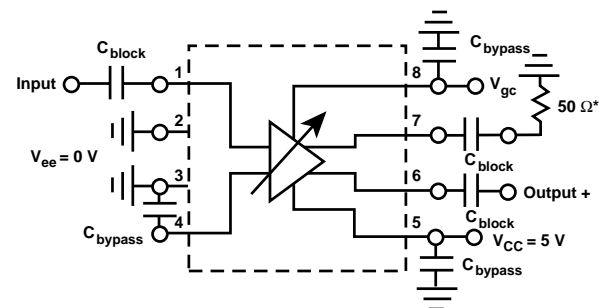

* Optional: For Single-Ended Output operation, Pin 7 may be left unterminated (no C_{block} or $50\ \Omega$)

IVA-05208 Absolute Maximum Ratings

Symbol	Parameter	Units	Absolute Maximum ^[1]
$V_{CC}-V_{ee}$	Device Voltage	V	8
	Power Dissipation ^[2,3]	mW	600
	Input Power	dBm	+14
$V_{gc}-V_{ee}$		V	7
T_J	Junction Temperature	°C	150
T_{STG}	Storage Temperature	°C	-65 to 150

Thermal Resistance^[2]:

$$\theta_{jc} = 150^{\circ}\text{C}/\text{W}$$

Notes:

1. Permanent damage may occur if any of these limits are exceeded.
2. $T_{CASE} = 25^{\circ}\text{C}$.
3. Derate at $6.67 \text{ mW}/^{\circ}\text{C}$ for $T_C > 60^{\circ}\text{C}$.

IVA-05208 Electrical Specifications^[1], $T_A = 25^{\circ}\text{C}$

Symbol	Parameters and Test Conditions: ^[2] $V_{CC} = 5 \text{ V}$, $V_{ee} = 0 \text{ V}$, $V_{gc} = 0 \text{ V}$, $Z_O = 50 \Omega$	Units	Min.	Typ.	Max.
Gp	Power Gain ($ S_{21} ^2$) $f = 0.5 \text{ GHz}$	dB	25	30	
ΔGp	Gain Flatness $f = 0.05 \text{ to } 1.0 \text{ GHz}$	dB		± 0.8	
$f_{3\text{dB}}$	3 dB Bandwidth ^[3]	GHz	1.2	1.8	
GCR	Gain Control Range ^[4] $f = 0.5 \text{ GHz}$ $V_{gc} = 0 \text{ to } 5 \text{ V}$	dB	25	30	
ISO	Reverse Isolation ($ S_{21} ^2$) $f = 0.5 \text{ GHz}$ $V_{gc} = 0 \text{ to } 5 \text{ V}$	dB		45	
VSWR	Input VSWR $f = 0.05 \text{ to } 1.5 \text{ GHz}$ $V_{gc} = 0 \text{ to } 5 \text{ V}$ Output VSWR $f = 0.05 \text{ to } 1.5 \text{ GHz}$ $V_{gc} = 0 \text{ to } 5 \text{ V}$			2.0:1 2.5:1	
NF	50 Ω Noise Figure $f = 0.5 \text{ GHz}$	dB		9	
$P_{1\text{dB}}$	Output Power at 1 dB Gain Compression $f = 0.5 \text{ GHz}$	dBm		-3	
V_{OUT}	Peak-to-Peak Single-Ended Output Voltage $f = 0.5 \text{ GHz}$	mVpp		450	
IP_3	Output Third Order Intercept Point $f = 0.5 \text{ GHz}$	dBm		7	
t_D	Group Delay $f = 0.5 \text{ GHz}$	psec		400	
I_{CC}	Supply Current	mA	25	35	50

Notes:

1. The recommended operating voltage range for this device is 4 to 6 V. Typical performance as a function of voltage is on the following page.
2. As measured using Input Pin 1 and Output Pin 6, with Output Pin 7 terminated into 50 ohms and Input Pin 4 at AC ground.
3. Referenced from 50 MHz Gain.
4. The recommended gain control range for these devices for dynamic control is 0 to 4.2 V. Operation at gain control settings above 4.2V may result in gain increase rather than gain decrease.

IVA-05208 Typical Performance, $T_A = 25^\circ\text{C}$, $V_{CC} = 5\text{ V}$, $V_{ee} = 0\text{ V}$

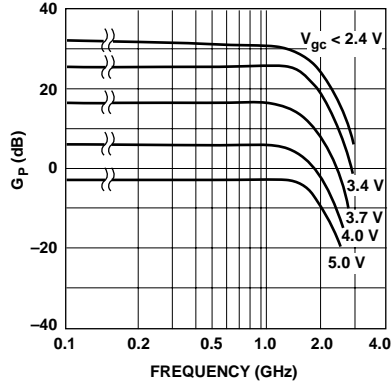

Figure 1. Typical Variable Gain vs. Frequency.

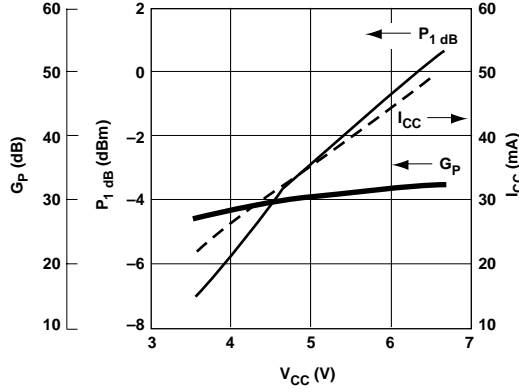

Figure 2. Power Gain and $P_1\text{ dB}$ at 0.5GHz and I_{CC} vs. Bias Voltage with $V_{gc} = 0\text{ V}$.

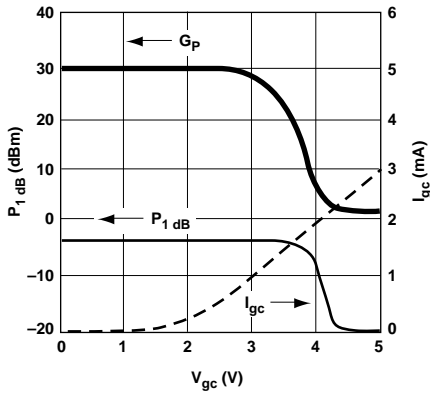

Figure 3. Power Gain and $P_1\text{ dB}$ at 0.5GHz and I_{gc} vs. Gain Control Voltage.

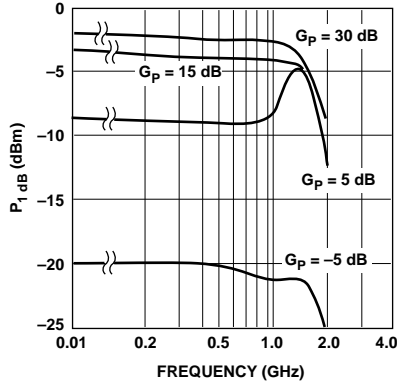

Figure 4. $P_1\text{ dB}$ vs. Frequency.

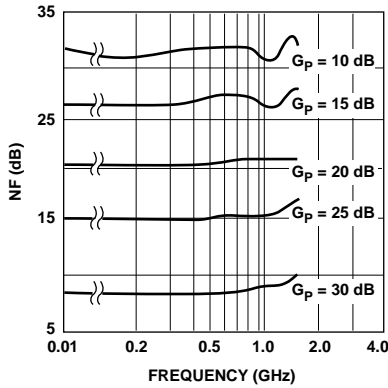

Figure 5. Noise Figure vs. Frequency.

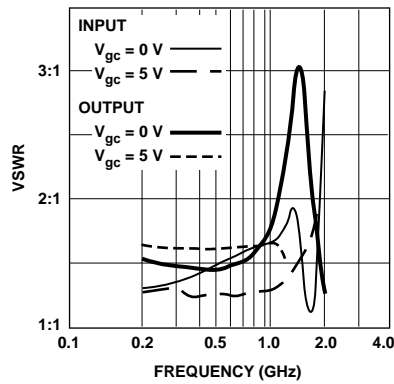

Figure 6. Input and Output VSWR vs. Frequency, $V_{gc} = 0 - 5\text{ V}$.

IVA-05208 Typical Performance, continued, $T_A = 25^\circ\text{C}$, $V_{CC} = 5\text{ V}$, $V_{ee} = 0\text{ V}$

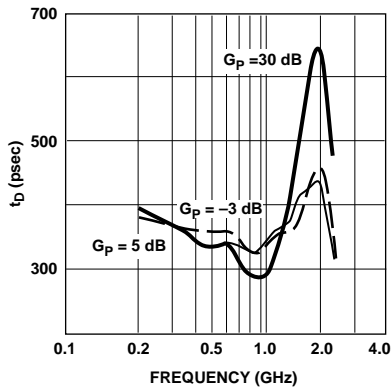

Figure 7. Group Delay vs. Frequency.

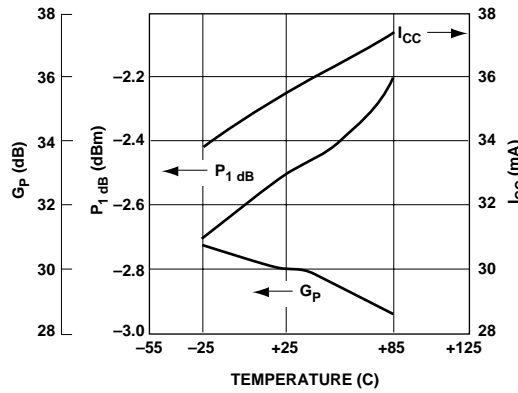
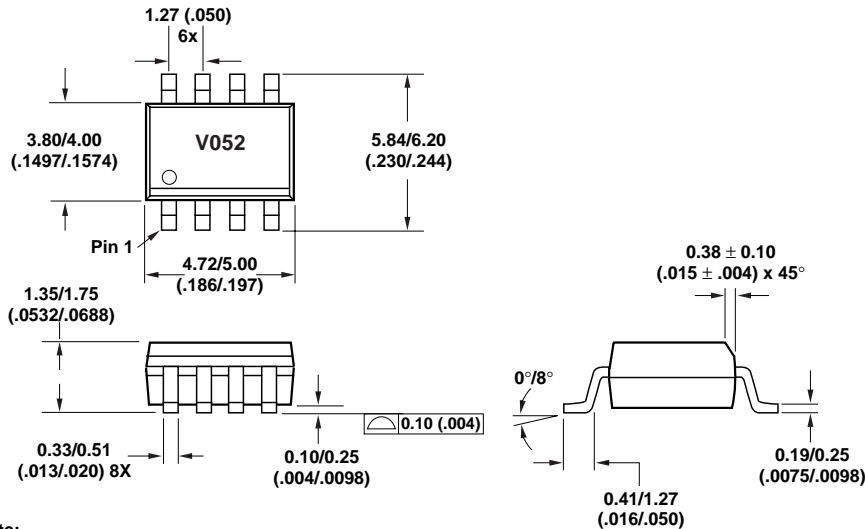

Figure 8. Power Gain and $P_{1\text{ dB}}$ at 0.5GHz and I_{CC} vs. Case Temperature with $V_{gc} = 0\text{ V}$.

IVA-05208 Part Number Ordering Information

Part Number	Number of Devices	Container
IVA-05208-TR1	1,000	7" Reel
IVA-05208-STR	10	Strip

SO-8 Package Dimensions



Note:
1. Dimensions are shown in millimeters (inches).

This datasheet has been download from:

www.datasheetcatalog.com

Datasheets for electronics components.